

Overflow valve, inline-design, pilot operated for liquids and gases
up to 130 °C

Technical Data

Connection	RP 824 DN 100 - 800 RP 825 DN 100 - 400
Nominal Pressure	PN 10 - 25
Inlet Pressure	2 - 20 bar in 3 setting ranges
Differential Press.	min. 2 bar
K_{vs} -value	60 - 2100 m ³ /h
Tightness	acc. VDI/VDE-guideline 2174 (leakage rate $\leq 0.05\%$ of K_{vs} -value)

Description

Medium-controlled overflow valves are simple control valves offering accurate control while being easy to install and maintain. They control the pressure upstream of the valve without requiring pneumatic or electrical control elements.

The RP 824 and RP 825 overflow valves are pilot-controlled control valves of tubular design consisting of a main valve, a pilot valve connected with the main valve via pipes and a restrictor assembly with built-in strainer. The valve cone is fitted with a metallic seal.

When the pipeline is depressurised the main valve is kept closed by a preloaded spring. To open the valve a pressure difference ($p_1 - p_2$) of at least 2 bar is required. When the inlet pressure is above the set pressure the pilot valve is kept open by its control mechanism. Restrictor D1 produces a pressure drop causing the outlet pressure to be almost equal to the pilot pressure in the main valve. The inlet pressure overcomes the pilot pressure and closing force of the spring and opens the main valve.

When the inlet pressure has reached the set pressure, the pilot valve restricts the flow. This causes the pilot pressure to rise and push the main valve piston into a controlling position in which opening and closing forces are in balance. When the inlet pressure falls below the set pressure the pilot valve closes. The pilot pressure is equal to the inlet pressure, the forces acting on the piston are in equilibrium and the main valve is kept closed by its spring. The restrictors are used to optimise the control characteristics. The bypass line around D2 which is fitted with a non-return valve, ensures quick closing.

The valve is piped internally. The G ½ pulse lines must be installed on-site.

The valve can be fitted with electrical limit switches.

The RP 824 and RP 825 overflow valves differ from each other by their size and K_{vs} ratings.

OPTIONS

- Special versions on request

Operating instructions, Know How and Safety instructions must be observed.

The pressure has always been indicated as overpressure.

We reserve the right to alter technical specifications without notice.

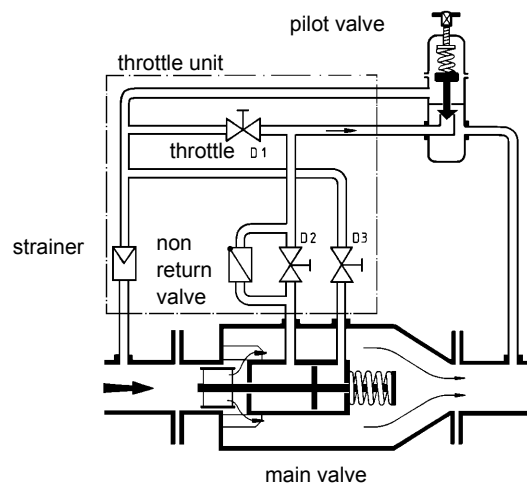
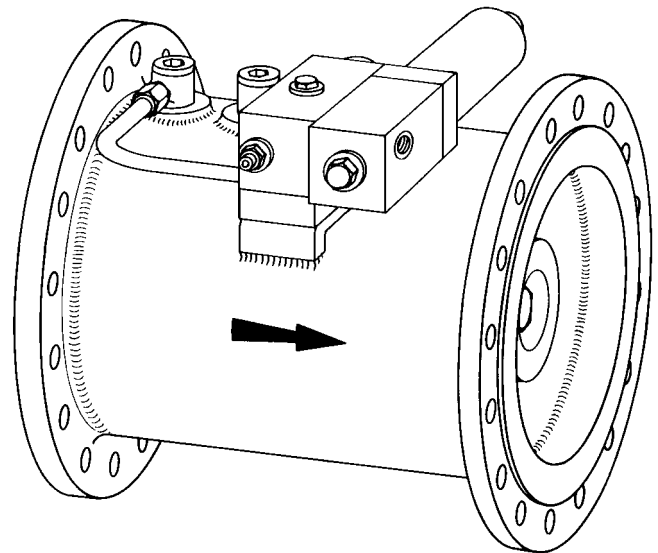

K_{vs} -values [m ³ /h]						
	nominal diameter DN					
type	100	125	150	200	250	300
824	60	100	120	180	250	400
825	180	200	250	400	600	800

K_{vs} -values [m ³ /h]							
	nominal diameter DN						
type	350	400	450	500	600	700	800
824	600	800	1100	1200	1800	2000	2100
825	1200	1800					

Setting Ranges [bar], Nominal Pressure		
2 - 5	4 - 12	10 - 20
PN 10	PN 16	PN 25

The pressure has always been indicated as overpressure.

Pressure Control Valves

RP 824, 825

Overflow valve, inline-design, pilot operated for liquids and gases up to 130 °C

Materials		
Temperature	80 °C	130 °C
Body	steel welded optional CrNiMo-steel welded	
Internals	CrNiMo-steel	CrNiMo-steel
Valve Seal	CrNiMo-steel	CrNiMo-steel
O-ring	NBR	EPDM
Pilot Valve		
Sense Lines	CrNiMo-steel	CrNiMo-steel
Throttle Unit		

Dimensions [mm] RP 824													
size	nominal diameter DN												
	100	125	150	200	250	300	350	400	450	500	600	700	800
A	300	325	350	400	450	500	550	600	650	700	800	900	1000
B max.	200	200	220	240	270	300	320	350	380	400	450	500	550
E max.	270	270	270	270	270	270	270	270	270	270	270	270	270

Weights [kg] RP 824													
PN	nominal diameter DN												
	100	125	150	200	250	300	350	400	450	500	600	700	800
16	60	60	65	75	120	150	190	240	300	360	420	480	540
25	75	75	80	90	135	165	220	280	360	400	460	580	720

Dimensions [mm] RP 825									
size	nominal diameter DN								
	100	125	150	200	250	300	350	400	
A	350	400	480	600	730	850	980	1100	
B max.	220	240	270	300	320	350	400	450	
ø D max.	360	400	425	485	555	620	730	845	
E max.	270	270	270	270	270	270	270	270	

Weights [kg] RP 825									
PN	nominal diameter DN								
	100	125	150	200	250	300	350	400	
16	85	110	125	170	220	270	340	400	
25	90	115	135	180	240	300	370	430	

Special designs on request.
The pressure has always been indicated as overpressure.
Mankenberg reserves the right, to alter or improve the designs or specifications of the products described herein without notice.

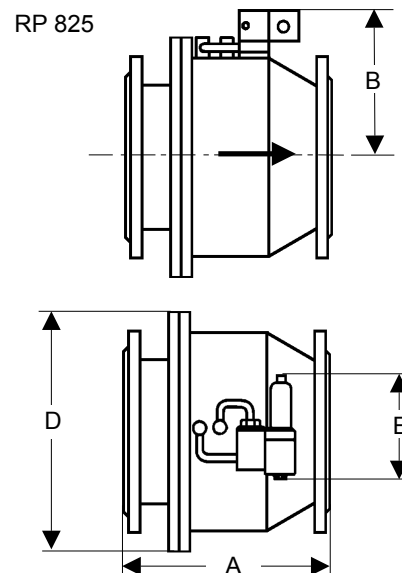
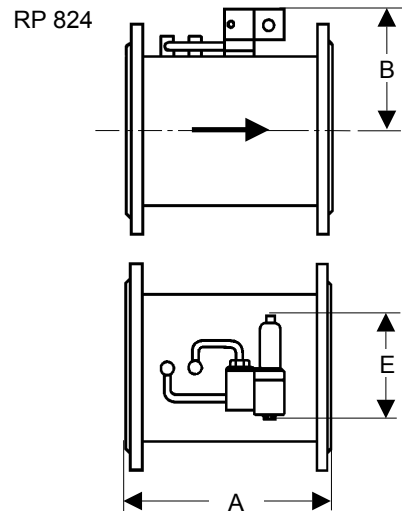

Recommended Installation

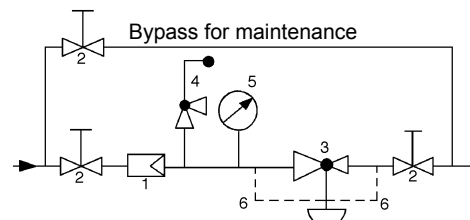

- 1 Strainer
- 2 Shutoff Valve
- 3 Overflow Valve
- 4 Safety Valve
- 5 Pressure Gauge
- 6 Sense Line

WIR REGELN DAS SCHON
FIRMLY IN CONTROL

MANKENBERG